

DIRECTIONS (PLEASE READ CAREFULLY!)

- 1) Assemble unit as shown. Place J-tube into License plate holder and insert locking pin. Remove philips head set screw and slide each V-bracket on arm in opposite directions. Insert Set screws into V-brackets and tighten with supplied allen wrench. Re install Philips head set screw in arm (to prevent brackets from sliding off).
- 2) Slide 1 1/2 knob thru loop in the end of trunk strap. Place onto J-tube about 8 inches from trunk of car and tighten.
- 3) Secure trunk strap(s) on edges of trunk and pull TIGHT!!! (to remove flexing).
- 4) Mount bikes in opposite directions and push bike vertical frame tube into V-bracket first and secure with velcro straps (do not over tighten). Attach 20" velcro strap around bike frame thru the front wheel to secure wheel. Make sure bikes are as close to the vehicle as possible and secure inside bike's pedal to upright.

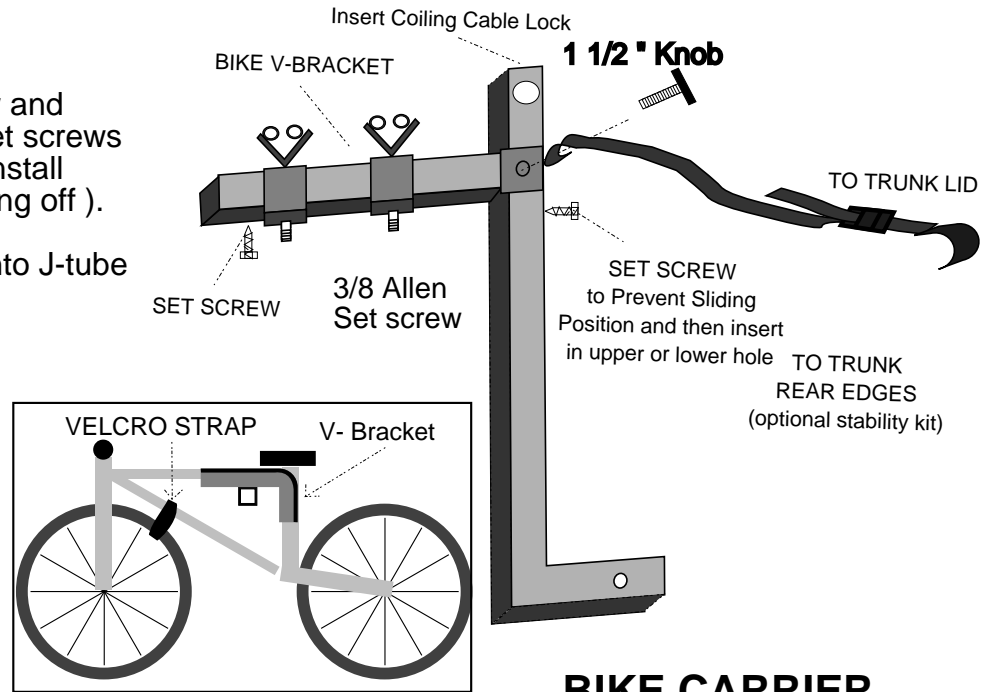

BIKE CARRIER

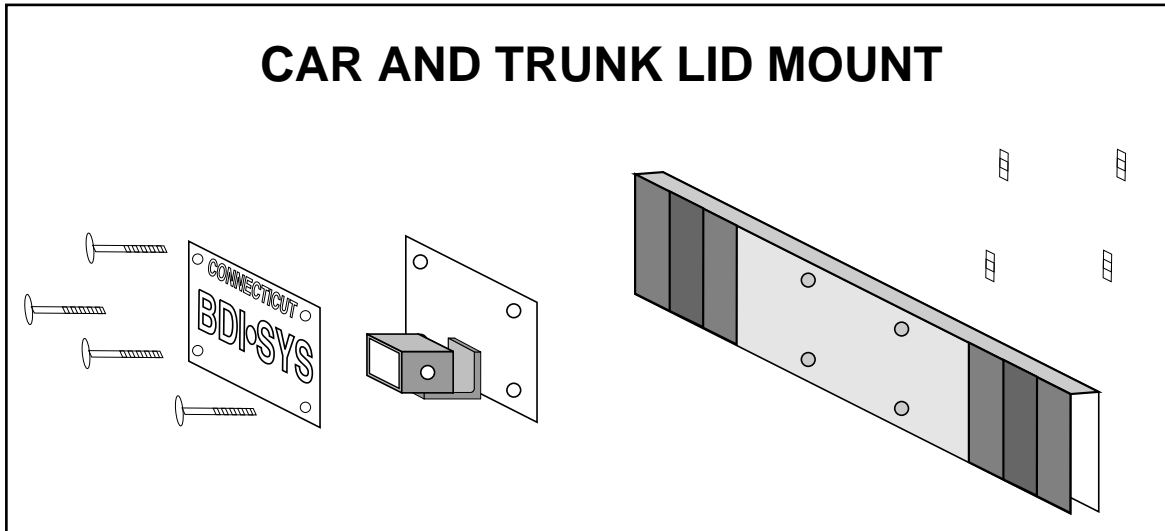

CAR AND TRUNK LID MOUNT

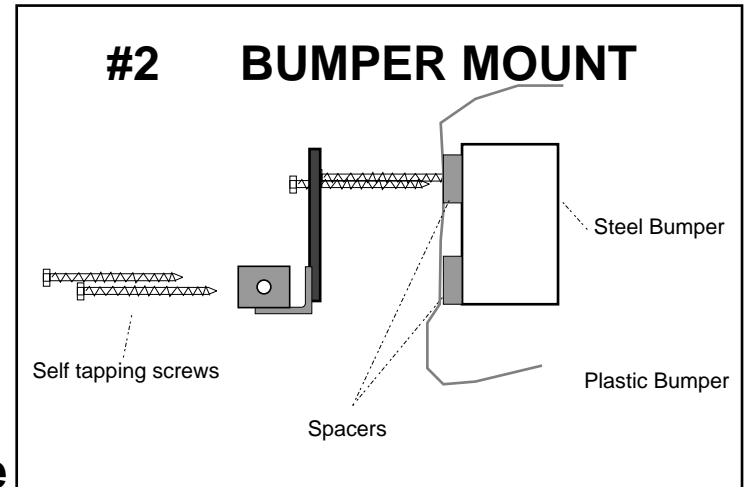

#2 BUMPER MOUNT

WARNING: All straps and knobs must be tightened before each use to insure safety of both vehicle and bikes. BDI assumes no liability for improper use or installation of their products.

ANY QUESTIONS CALL!! 561-433-3818